

mimcook®

# TECHNICAL MANUAL

and maintenance



# INDEX

	PAGE
Technical characteristics	3-5
Recommendations and implementation	5-8
Mimcook maintenance	9
Problem identification	10-15
Solutions	16-26



# TECHNICAL CHARACTERISTICS

mimcook go

Mimcook Pro is distributed in 2 models with the following characteristics:

**Mimcook Go GP:** Gas: G-31; Presión: 37 mbar; Cat: I3P

Quemador	Diámetro	Consumo máx	Consumo 1/2	Consumo mín	Regulación del aire
Interior	0.95mm	2.5kW	2.3kW	2.3kW	Fija
Central	1.45mm	5.6kW	5.0kW	5.0kW	Fija
Conjunto	-	8kW	7kW	4kW	Fija
Piloto	0.27mm	0.5kW	0.5kW	0.5kW	Fija

**Mimcook Go GN:** Gas: G-20; Presión: 20 mbar; Cat: I2H

Quemador	Diámetro	Consumo máx	Consumo 1/2	Consumo mín	Regulación del aire
Interior	1.45mm	3kW	2.9kW	1.6kW	Fija
Central	2.20mm	5.8kW	5.1kW	2.8kW	Fija
Conjunto	-	8.5kW	7.5kW	4.5kW	Fija
Piloto	0.5mm	0.5kW	0.5kW	0.5kW	Fija

## Características eléctricas

Tensión de la alimentación	95-250V
Frecuencia	47-63Hz
Potencia eléctrica	55W

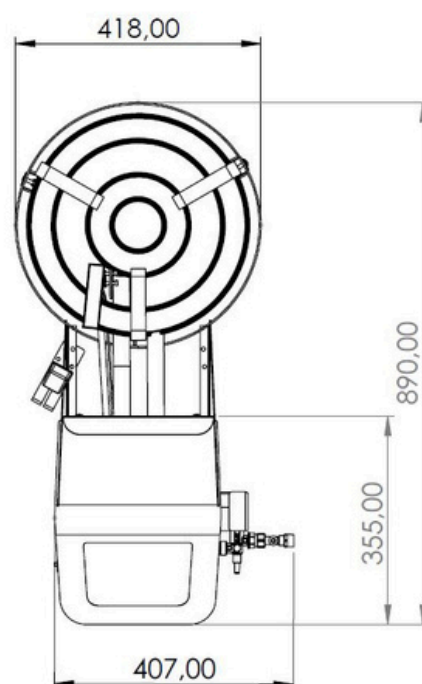
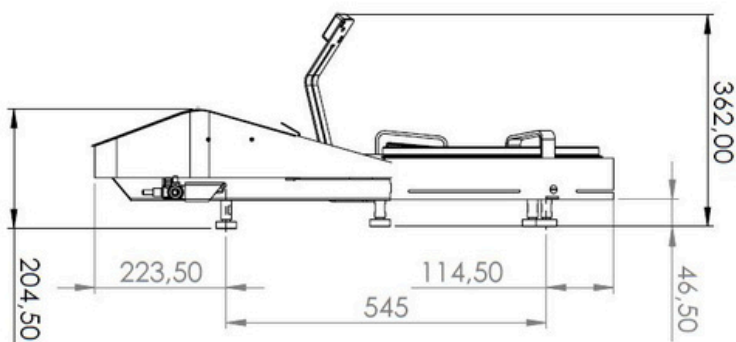

# mimcook pro

Mimcook Pro is distributed in 2 models with the following characteristics:

**Mimcook Pro GP:** Gas: G-31; Presión: 37 mbar; Cat: I3P

Quemador	Diámetro	Consumo máx	Consumo 1/2	Consumo mín	Regulación del aire
Interior	0.95mm	2.5kW	2.3kW	2.3kW	Fija
Central	1.45mm	5.6kW	5.0kW	5.0kW	Fija
Exterior	1.55mm	6.6kW	5.8kW	5.8kW	Fija
Conjunto	-	14kW	13.5kW	13.5kW	Fija
Piloto	0.27mm	0.5kW	0.5kW	0.5kW	Fija

**Mimcook Pro GN:** Gas: G-20; Presión: 20 mbar; Cat: I2H

Quemador	Diámetro	Consumo máx	Consumo 1/2	Consumo mín	Regulación del aire
Interior	1.45mm	3kW	2.9kW	1.6kW	Fija
Central	2.20mm	5.8kW	5.1kW	2.8kW	Fija
Exterior	2.85mm	10kW	9.1kW	5.7kW	Fija
Conjunto	-	18.6kW	16.5kW	10kW	Fija
Piloto	0.42mm	0.5kW	0.5kW	0.5kW	Fija

## Características eléctricas

Tensión de la alimentación	95-250V
Frecuencia	47-63Hz
Potencia eléctrica	55W

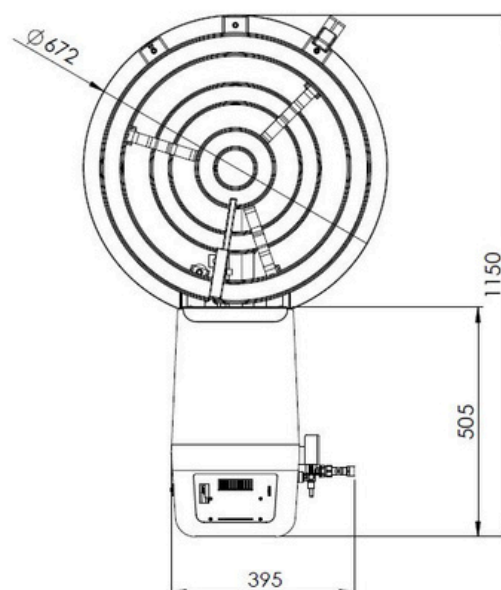
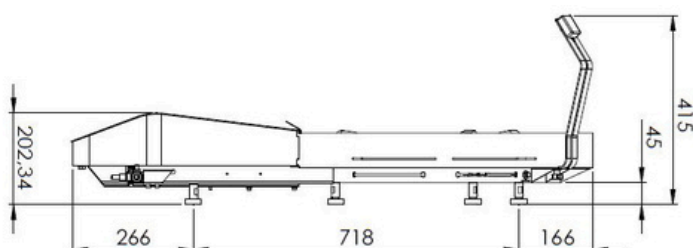

# RECOMMENDATIONS AND IMPLEMENTATION



We ask that you read the entire document before working with the client.  
If you have any questions, please contact us at [hola@mimcook.com](mailto:hola@mimcook.com)



For any intervention with mimcook the following tools are required:

- Number keys: 6, 8, 10, 11, 13, 16, 23
- Allen key set
- Wrench
- Pliers
- Flat and star screwdrivers of different sizes
- Electrical circuit tester (in case of electrical failure)



Before starting any repair, it is essential to always turn off and disconnect the mimcook from the electrical outlet and disconnect or cut off the gas supply that supplies it.



## Start-up

The installation of mimcook is simple, although it must be done by qualified personnel. Mimcook has an electrical connection on the left side and a gas connection (natural or propane) on the right side. The gas installation must comply with the regulations in force in the place where it is installed.

### Mimcook with keyboard

The system menu allows us to configure certain special features of the mimcook, as well as check its correct operation.

To access it, we must press the F1 button (top left), the left button and the bottom button at the same time and turn on the mimcook while holding them down.

Once turned on, it will show us the Parameters and Autotest menu.

In the Parameters menu we will find everything related to the mimcook in front of us. All the specifications here must remain unchanged, except one, "PILOT FLAME TIME", which we can lengthen so that the mimcook does not have to be turned on continuously.



## Mimcook with screen

To correctly start up the mimcook with screen, we must ask the customer for the Wi-Fi password and enter it in the Wi-Fi menu.

Next, we will hit update and wait a few seconds for the mimcook to update.

If you don't have Wi-Fi, you can download the latest version of the operating system from the following link and put it on a pendrive. To update manually, connect the pendrive to the mimcook and turn on the mimcook. The mimcook will update automatically.

**<https://ixd-pantallas.loading.net/MIMCOOK/DCIOT.PKG>**

Once the mimcook is updated, we will enter the configuration menu and re-enter the wifi password, connecting it with the button 

This mimcook also has a hidden menu, which we access from the “Parameters” menu. When we press to go to the second menu, we will get a security warning. To get past it we must hold down the “Yes” button for 10 seconds. At this point a menu will appear with some selectable items:

- Firepower: Allows changing powers during cooking
- Phase time: Allows changing times during cooking
- Phase Change: Allows you to move within the recipe easily
- Auto Off: Causes the pilot light to turn off after a certain period of time.

Ideally for customers the “Phase Time and Auto Off” should be disabled 

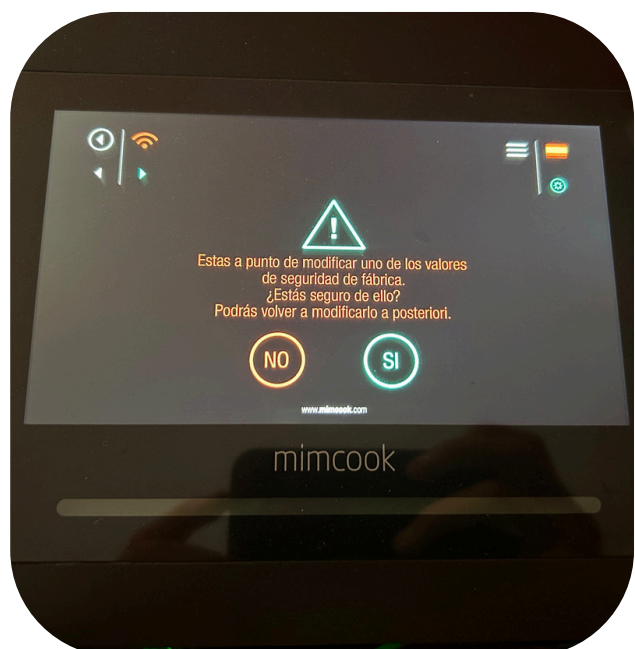

# MIMCOOK MAINTENANCE

## Cleaning

Cleaning the rings after each use is essential for proper maintenance of the machines.

To do this, it is very important to use a damp cloth, not completely wet, to prevent it from releasing water and that water from entering the paella pan, since this would end up causing a major corrosion problem. Once clean, dry it with a dry cloth.

The rims can be cleaned with soaps and non-abrasive chemical products, as long as they do not damage the enamel. Never spill the product or water on the rims. If corrosion is detected, contact their technical service to proceed with a change of rims.

Any holes in the paella pan that may be blocked by dirt should be cleaned with a wooden stick so as not to alter the size of the holes.



Lack of cleaning can cause serious problems in mimcooks. If the flames cannot escape through the burner due to excess dirt, **IT IS ESSENTIAL TO CLEAN IT IMMEDIATELY**. Failure to do so could cause the flame to flash back, rendering the mimcook unusable.

# PROBLEM IDENTIFICATION

## Problems with gas supply

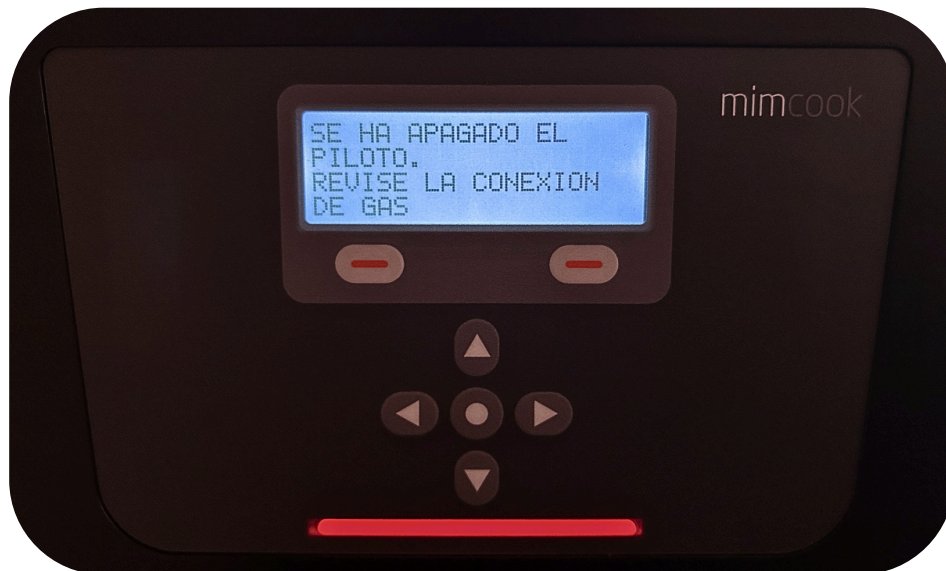

The sudden shutdown of mimcooks can be due to several reasons. To do this we must carry out the following checks:

### **The mimcook turns off at random times.**

In this case we must check if the thermocouples are in a good position. They must be touching the flame, as close as possible to the pilot flame but without touching it. On the other hand, the obstruction of the pilot flame holes can also be a cause of gas shut-offs.

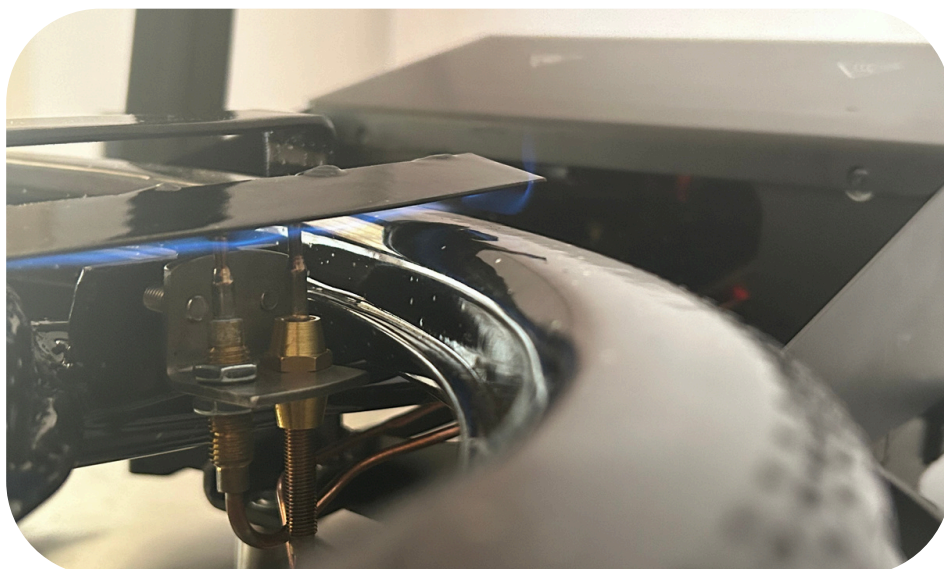

## Problems with gas supply

Are the mimcooks unprotected from drafts or kitchen ventilation? If the mimcooks are unprotected from the wind, the safety system may be activated.

### **The mimcook turns off at specific times**

It turns off when we stop pressing the inlet valve

The connection to the universal thermocouple located at the top of the valve should be seen or a thermocouple change should be considered.

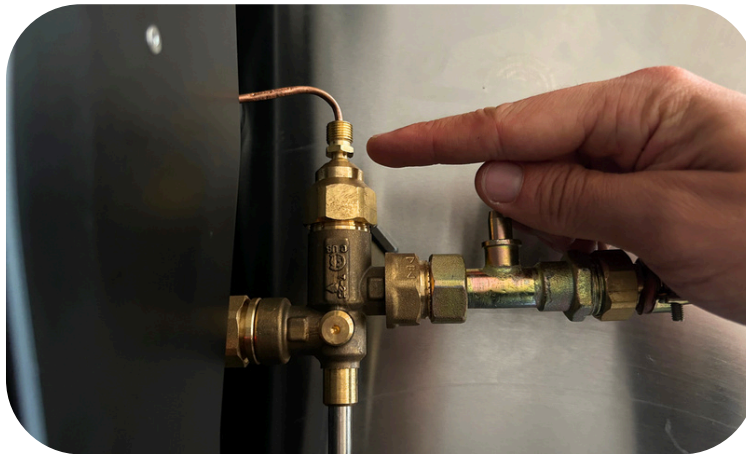

### **Some of the fire levels of a ring do not work**

This problem can be caused by two reasons:

- The solenoid valve is not properly connected to the electronics
- The solenoid valve is not working and needs to be replaced.

To find out if it is the latter, we will identify the solenoid valve and select the fire and level manually. If we do not hear the sound of the valve opening with a “clack” when selecting it, it must be replaced.

## Problems with ignition



### Ignition problems due to gas

Gas ignition problems are identified in the ignition bar that appears once the recipe and diners have been selected.

If the power bar does not appear, it means that the thermocouple that connects to the electronics is not emitting the desired signal. This may be due to wear or a bad connection. Remember that each mimcook comes with one of these spare thermocouples.

If the bar gets stuck in a specific spot without moving forward or goes up and down in an uncontrolled manner, it will be a problem of not being grounded.

To do this, we must screw both the thermocouple area (in the pilot light) and the mimcook body box tightly.



Using blowtorches or direct flame on thermocouples shortens their life and reduces their sensitivity. It is important to use lighters and apply them to the pilot light and not directly on the thermocouples.

## Problems with ignition

### **The pilot light does not light but the rest of the burners do**

This may be due to several reasons:

- The pilot light tube has become dislodged from the gas outlet
- The solenoid valve is not properly connected to the electronic board
- The cliclé is clogged. To do this we recommend unscrewing it and passing it under compressed air (from a coffee machine, for example).
- The solenoid valve is not working. If we do not hear a “click” when selecting the recipe on the mimcook, the valve is not working properly and must be replaced.

### **Ignition problems due to electrical causes**

For electrical ignition problems, it is recommended to perform the necessary tests with a circuit tester. Electrical problems can be due to several reasons:

- Poor condition of the power cord or plug.
- Breakage of input or electronic fuses due to a power surge.
- Power supply problem.
- Flameback with partial or total damage due to lack of cleaning. If this is the case, the mimcook must be sent to the factory for repair.

[For spare parts or questions, you can contact us at hola@mimcook.com](mailto:hola@mimcook.com)

## Temperature measurement problems

Sometimes Mimcook may have a bad signal from the temperature sensor.

We must take into account that the Mimcook takes an average of the temperature of the area that the sensor focuses on.

To improve the sensitivity of the sensor, we recommend keeping it always clean with a damp cloth and tightly screwed to the base of the mimcook so that it focuses on the appropriate area.



On the other hand, if the sensor is not offering the correct temperature or the temperature measurement system has been blocked, the following signals will appear in the temperature signal instead of the temperature, depending on the version of the system:



## Temperature measurement problems

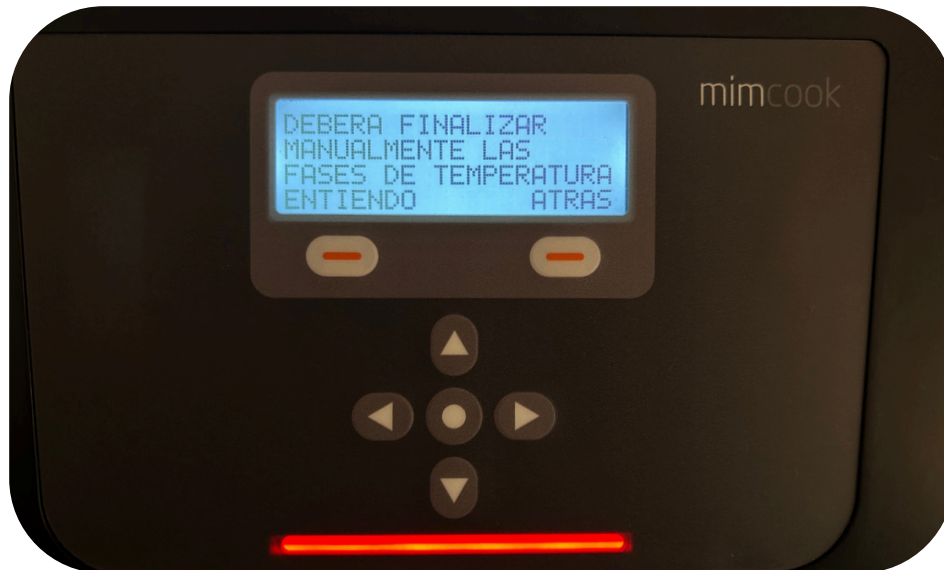

In the latest system updates, a temperature lock detector has been introduced. When this happens, the mimcook asks for a restart or to keep in mind that the temperature phases must be done in manual mode until the machine restarts.

To solve problems arising from temperature, we must ensure that the temperature sensor cable is not damaged and is properly connected to the electronics (the central and the sensor) and restart the mimcook.

If this is not the case and/or the problem persists, the cable must be replaced with a new one.

To order the cable you can do so at [hola@mimcook.com](mailto:hola@mimcook.com)

# PROBLEM SOLVING

	PAGE
Opening the mimcook	16-18
Changing the temperature probe	19-20
Universal thermocouple replacement	21
	22
Electronic thermocouple replacement	23-24
Changing rings	25-26
Adjustment and fixing of the legs	

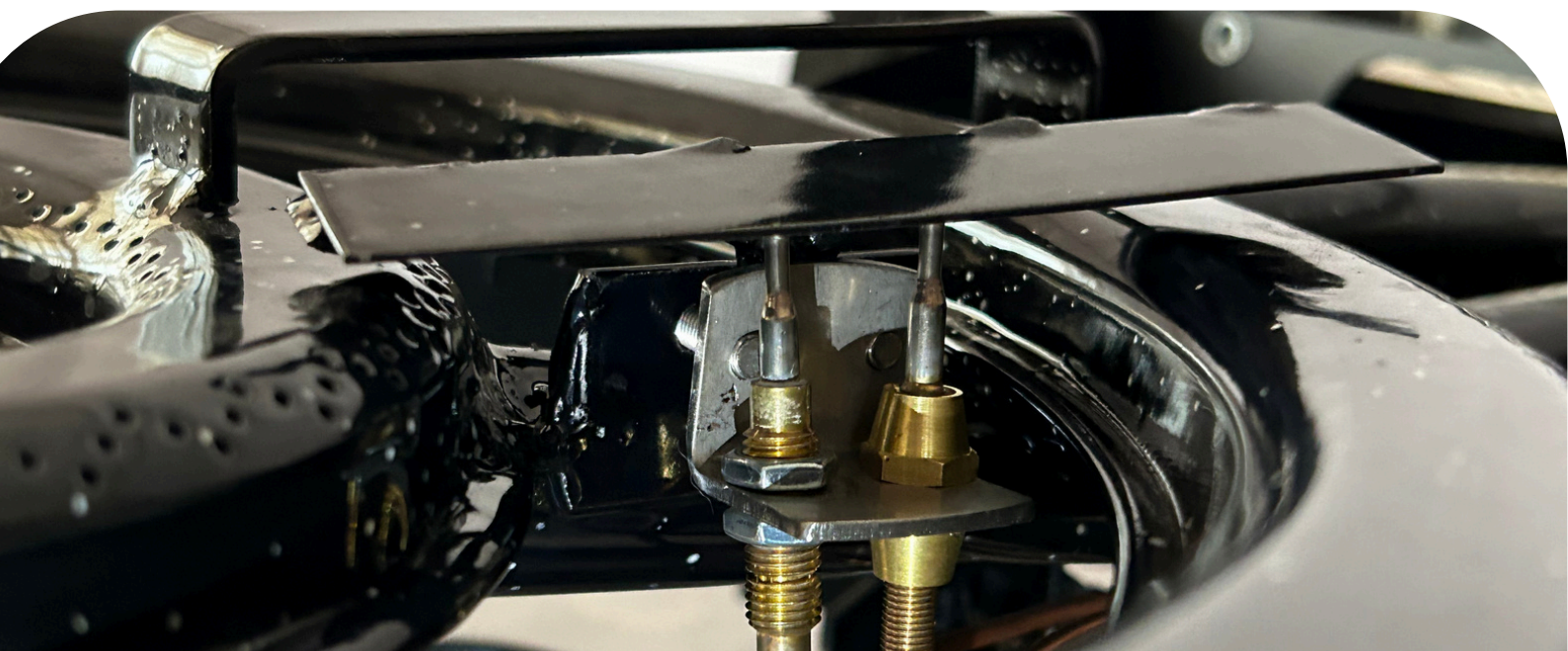

## Opening the mimcook

- 1 Unscrew the screws from under the screen.



- 2 Unscrew the screws from the flame arrester and remove.



3

Lift the cover. Do not remove it abruptly to avoid affecting the connections or electronics.

Unplug the connections and remove the cover.

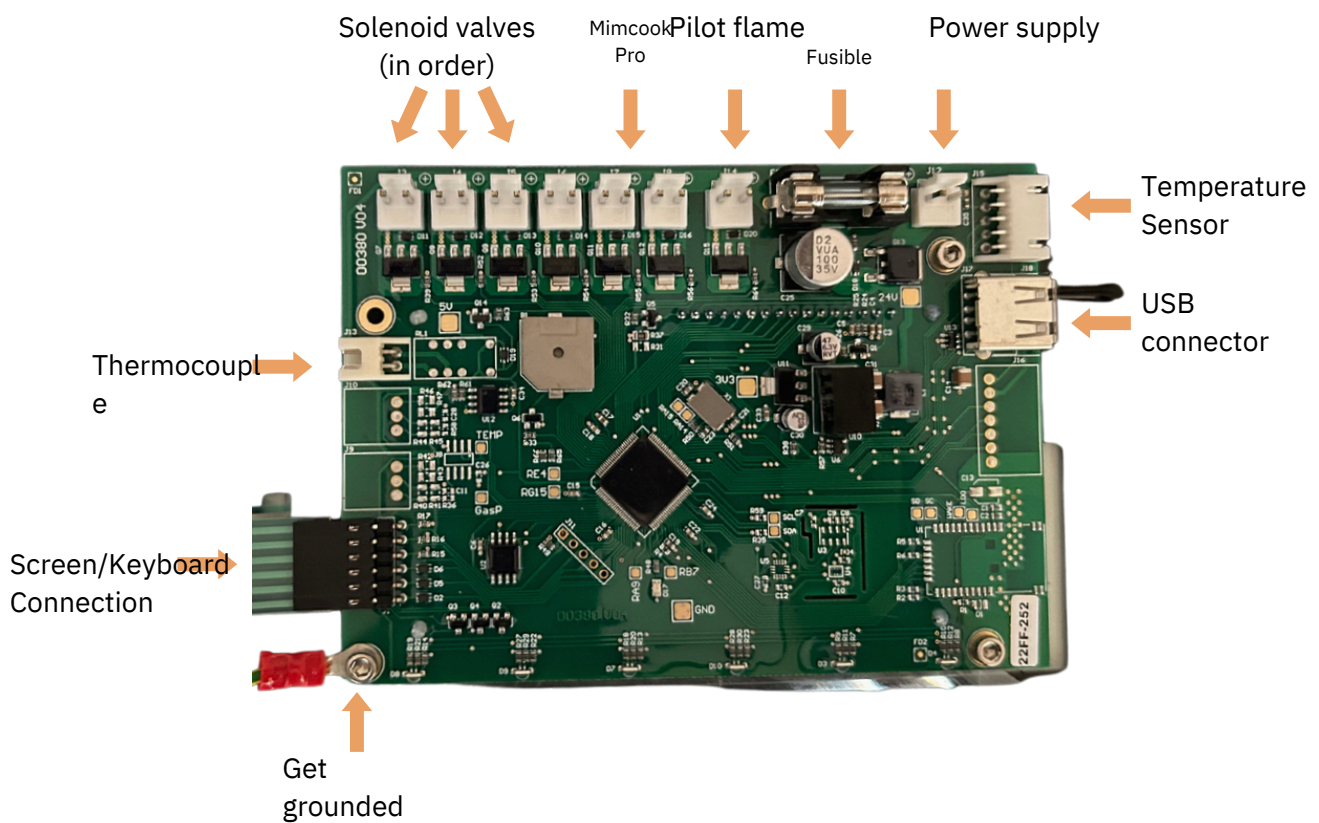

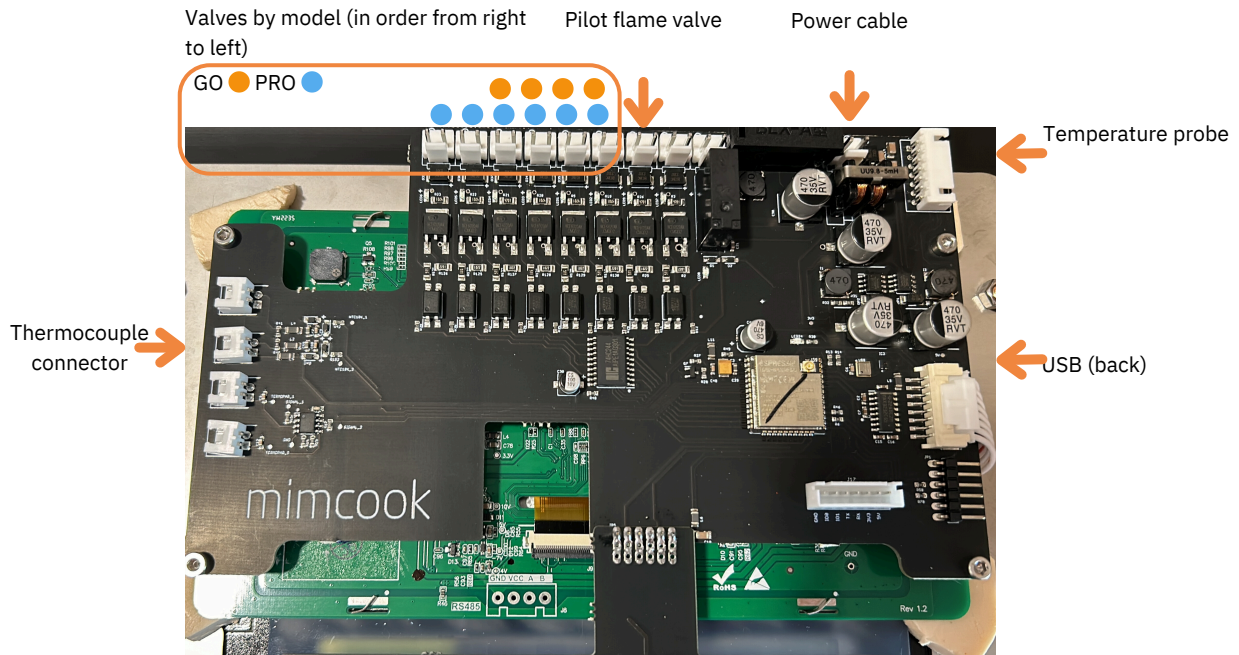

The mimcook may not be grounded.  
 To remove it, we recommend unscrewing the solenoid valve until the cable is removed.  
 If you want to add it to a mimcook that doesn't have it, contact us at [hola@mimcook.com](mailto:hola@mimcook.com)

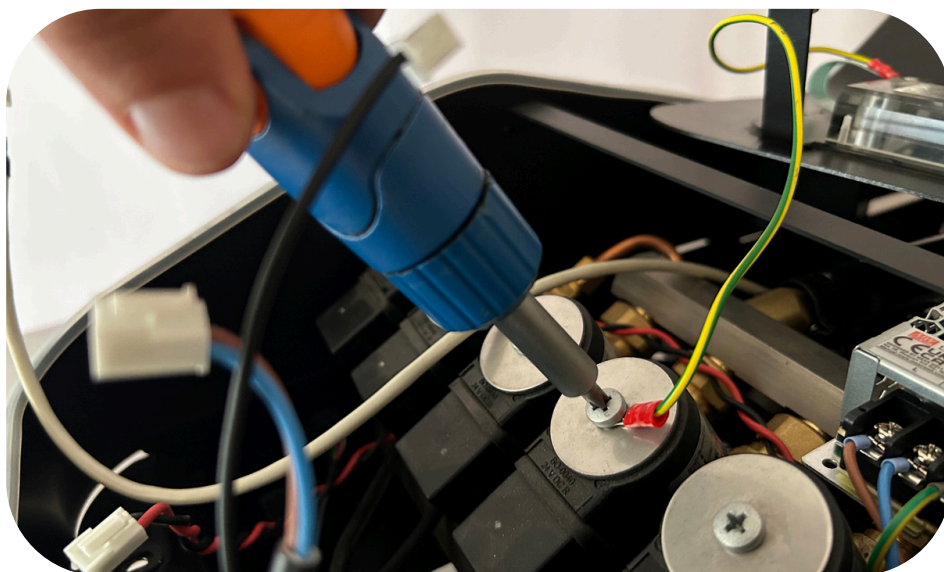

## Changing the temperature probe

- 1** Remove the cable from inside the mimcook body, unscrew the sensor arm and unhook the cable from the arm.



- 2** Unscrew the outer screws of the sensor arm and remove the cover.



3

The following steps are delicate, involving small parts that are essential for the proper functioning of the mimcook, especially the germanium lens (glass) and the fixing rubber, which are pressed in place and must not get dirty. Unscrew the internal screws, separating the chip from the arm.

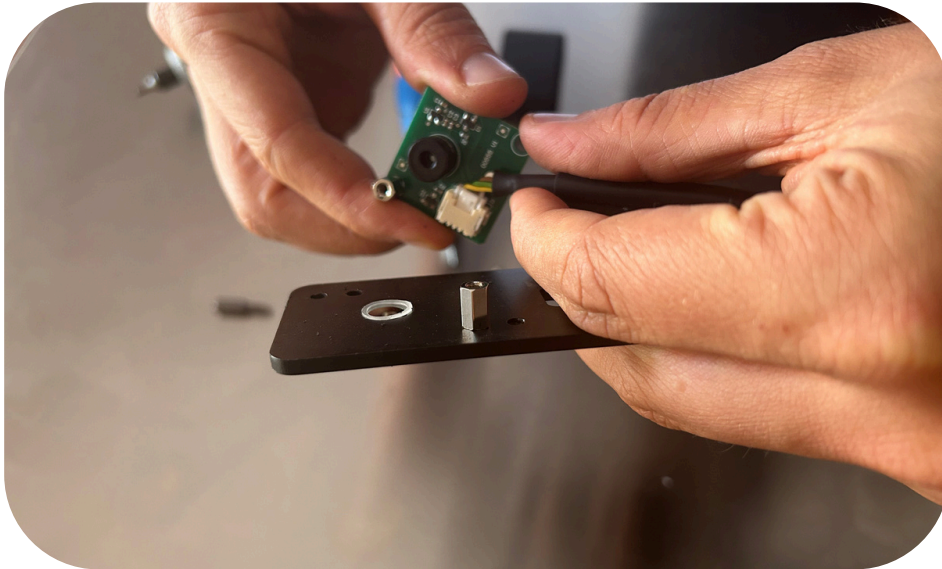

4

Unplug the switch, replace it and close the box again. Screw it in (outer screws) without tightening it too much. Place half of the cable in the cable gland and use a screwdriver to insert the other half. Turn the sensor and place the cable correctly on the other side. Pass the cable through the inside of the mimcook and connect it to the electronics.



## Universal thermocouple replacement

- 1** Unscrew the cap from the inlet valve and unscrew the thermocouple. When reassembling the new one, be careful not to force it, just secure it a little with a wrench, after placing it by hand.



- 2** Unscrew the thermocouple in the pilot light area to remove it. If preferred, the pilot light can be separated from the thermocouples using an Allen key. To reassemble, follow the reverse process.

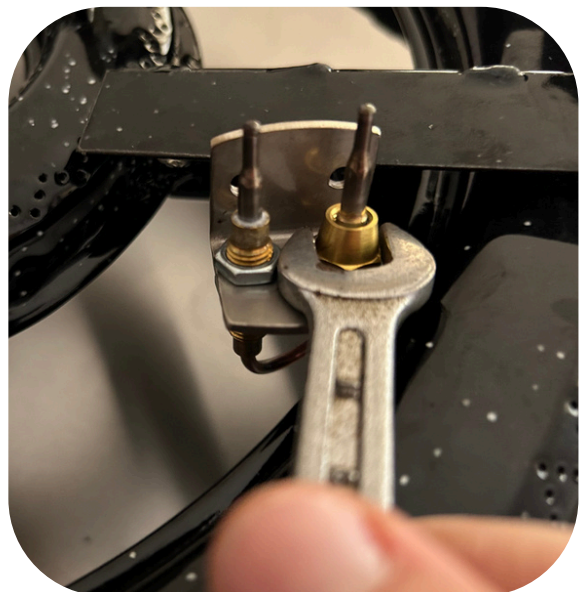

## Electronic thermocouple replacement

- 1 Unplug the thermocouple from the black adapter cable that connects to the electronics

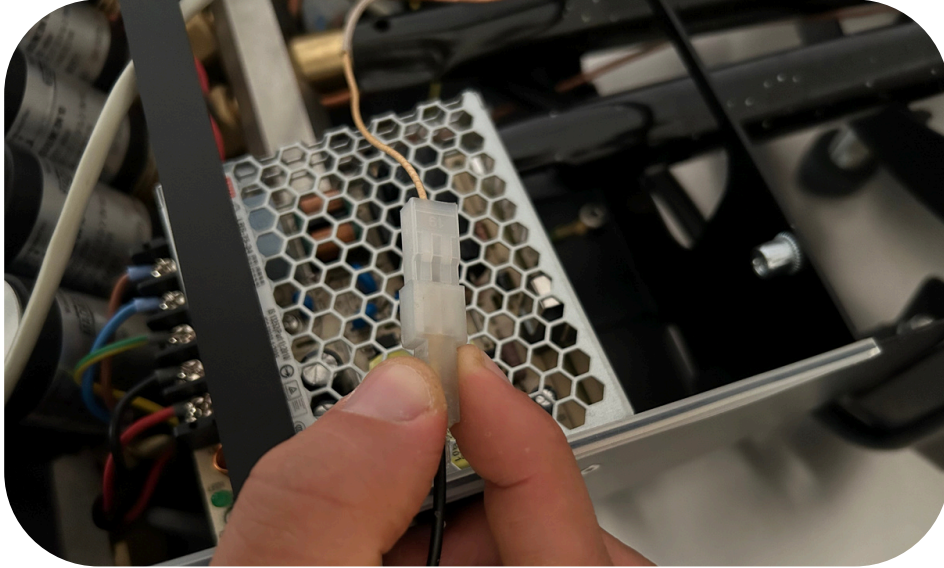

- 2 Unscrew the thermocouple in the pilot light area to remove it. If preferred, the pilot light can be separated from the thermocouples using an Allen key. To reassemble, follow the reverse process.



## Changing rings

- 1 After separating the thermocouples from the pilot light, remove the pilot light by pulling it towards the rings.

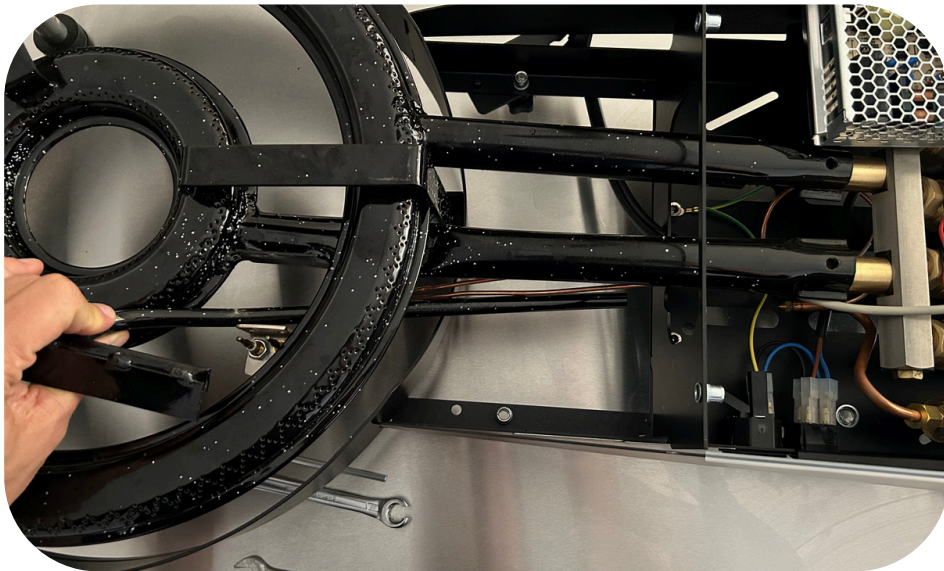

- 2 Next, secure the inner round-head screw on each leg and unscrew it with a flat-head screwdriver from the outside.



**3**

Remove the ring by applying pressure from above and outwards. Place the new ring ensuring that all the gas inlets fit (including the pilot light). Follow the reverse process to reconnect everything and close the mimcook.

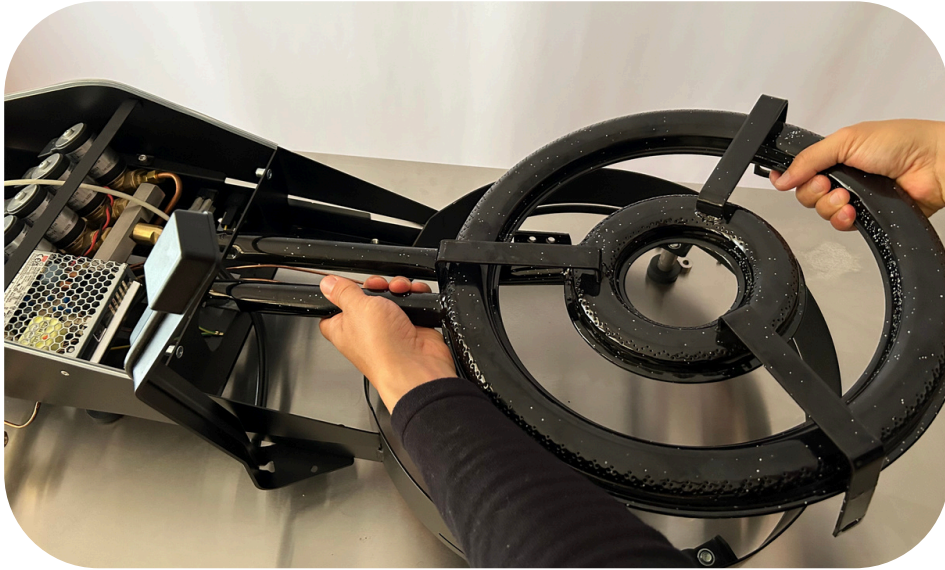

## Adjustment and fixing of the legs

**1**

Each of the mimcook legs is adjustable in height, allowing you to level the contents of the paella pan even if the surface on which the mimcook is placed is not flat. The mimcook legs are made up of two essential parts: 1. The leg and 2. The leg holder.

**2**

To adjust the height of the leg, unscrew the fixing as far as possible using a wrench. Then, turn the leg to raise or lower it.



- 3 Finally, when you reach the desired height, screw the clamp back on all the way and secure it with the wrench.



To ensure that the mimcook is level, we recommend placing a pan with a little water on top of the burner. Then, lower all the legs to the minimum setting. Then, adjust the necessary legs until the water is in the middle.